

# THE USE OF HONEYCOMB SEALS IN STABILIZING TWO CENTRIFUGAL COMPRESSORS

by

**Fouad Y. Zeidan**

Director of Engineering  
KMC, Inc.

West Greenwich, Rhode Island  
and

**Robert X. Perez**

Senior Reliability Engineer  
Citgo Petroleum Corporation  
Corpus Christi, Texas

and

**E. Morris Stephenson**

Senior Research Engineer  
Amoco Corporation  
Houston, Texas



*Fouad Y. Zeidan is Director of Engineering at KMC, Inc., in West Greenwich, Rhode Island. Prior to joining KMC, Dr. Zeidan held positions at Amoco Research Center, Imo Industries CentriMarc Division, and Qatar Fertilizer. He worked in maintenance and trouble shooting of rotating machinery, bearing design and failure analysis, vibration analysis, rotordynamic analysis, technical auditing of new machinery, and upgrading of existing equipment. At KMC, he is working*

*in the design and development of radial and thrust bearings for oil, process, and gas lubricated applications. He received his B.S.M.E. (1978), M.S.M.E. (1979), and Ph.D. (1989) degrees in Mechanical Engineering from Texas A&M University.*



*Morris Stephenson is a Senior Research Engineer employed by Amoco Corporation Research Center in Naperville, Illinois, and is assigned to the Applied Mechanics Group located in Houston, Texas. He works as a consultant to the refineries, chemical plants and production facilities of the Amoco subsidiaries, both domestic and foreign. He is responsible for providing solutions to machinery related problems through applied research in the areas of vibration analysis*

*and rotor bearing system dynamics.*

*Mr. Stephenson received his B.S.M.E. degree from Tennessee Technological University and has worked for Amoco 13 years in various engineering, maintenance, and rotating equipment assignments.*

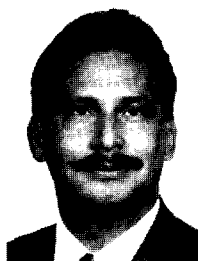

*Robert X. Perez is a Senior Reliability Engineer for the Citgo Corpus Christi Refinery. He has previously written and has been a coauthor on several papers in the field of machinery vibration. His primary duties include troubleshooting rotating equipment problems, leading root-cause failure analysis teams, and serving as the plant consultant in the areas of vibration analysis and rotordynamics. He was instrumental in the implementation of a computer based vibration*

*monitoring program and an onstream piping inspection program for his refinery, and was the first in his plant to promote the use of Weibull analysis techniques to analyze mechanical failure data.*

*Mr. Perez is a registered Professional Engineer in the State of Texas and a member of ASME and the Vibration Institute. He received his B.S.M.E. degree from Texas A&M University, and an M.S.M.E. degree from the University of Texas.*

---

## INTRODUCTION

The reliable operation of high performance turbomachinery depends to a large extent on the stability characteristics of critical components such as bearings, seals, and impellers. Hydrodynamic bearings have been known to be a source of instability. Improvements in their design and optimization has resulted in bearing configurations that are inherently more stable. Variable geometry tilting pad bearings are a direct outcome of the push for more stable bearings and increased turbomachinery reliability. As tilt pad bearings provided greater stability margins, the design and performance requirements for turbomachinery were further pushed to their limit. As a result, it is not uncommon to find machinery experiencing stability problems even with tilting pad bearings. The instabilities experienced with machines supported on tilting pad bearings pointed out the presence of destabilizing components in turbomachinery other than the bearings. It also showed that in

spite of the inherent stability characteristics of tilt pad bearings, there is a limit to their stabilizing capacity. This eventually lead to identifying other sources of instability in turbomachinery. Instabilities have been attributed to floating oil film seals, impeller aerodynamic forces, and labyrinth gas seals.

The stabilizing effects achieved by replacing labyrinth seals with honeycomb seals are described. Although honeycomb seals have been used for some time in high pressure compressors and other turbomachinery applications, their stabilizing influence has only recently been recognized. The pioneering work of Childs et al. [1,2,3], in the theoretical analyses and accompanying experimental investigations have had a significant influence on advancing the use of honeycomb seal technology. A major beneficiary of the application of honeycomb seals has been the space shuttle turbo pumps. There are other major applications for honeycomb seals but, for the most part, they have remained in a narrow area encompassing the aerospace industry and the higher performance turbomachinery applications.

The authors address how honeycomb seals were used to stabilize two process-type compressors. Two stability problems experienced on two different compressor configurations were solved using a common approach. These two cases should serve to enlighten users who might experience similar problems. It also sheds light on other sources of instability in turbomachinery, and some of the means available to counter their destabilizing effects. In both cases, the application of honeycomb seals was instrumental in enhancing the stability of each of the compressors.

### STABILITY EFFECTS OF SOME CRITICAL TURBOMACHINERY COMPONENTS

To help understand why rotating machinery experience stability problems, the stability characteristics of several critical components will be briefly discussed. This is not intended to be a comprehensive study of all relevant components in a machine, but merely of those that were addressed by the two case studies presented here. This introduction also provides background for some of the solutions considered in the two cases.

#### Hydrodynamic Bearings

##### Fixed Geometry Bearings

Journal bearings support the weight of the rotating shaft by developing a hydrodynamic pressure in the converging wedge as shown in Figure 1. The unsymmetric pressure profile in the oil film

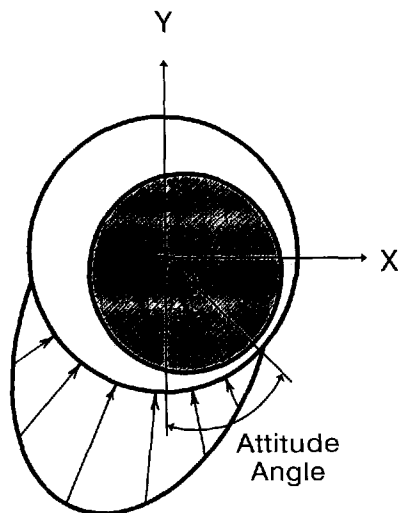

Figure 1. Hydrodynamic Pressure Profile in a Journal Bearing.

is characteristic of fixed geometry journal bearings. This gives rise to an attitude angle between the line of centers and the load vector. This characteristic, present in all fixed geometry journal bearings, is indicative of the presence of crosscoupling in the bearing. Crosscoupling characteristics are present in all rotating machinery operating in fluid film bearings or seals. Crosscoupling has no equivalent in other structural nonrotating equipment. It is the cross-coupled stiffness force that promotes self-excited vibrations and instabilities in rotating machinery. Vance [4] provides an excellent graphic presentation of the crosscoupled stiffness force. This presentation is reproduced in Figure 2. The destabilizing crosscoupled force is represented as a resultant of the force components due to the  $(K_{xy})$  and  $(K_{yx})$  stiffness terms. A positive  $(K_{xy})$  and a negative  $(K_{yx})$  will result in a net force that is tangential to the whirl orbit and in the direction of rotation. The term "forward whirl driving force" is used to describe such a destabilizing motion. Follower force and circulatory force are other expressions also used to describe the destabilizing crosscoupling force. The degree of crosscoupling is greatly influenced by the fluid rotation and circular geometry present in fixed geometry bearings.

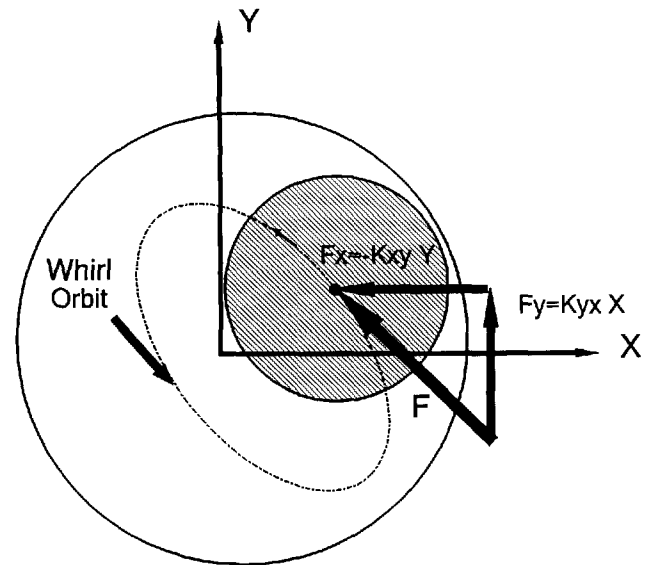

Figure 2. Crosscoupled Stiffness Force from Vance [4].

By reducing fluid rotation and/or altering the circular geometry, fixed geometry journal bearings can be made to achieve a higher stability threshold speed. The addition of grooves in journal bearings tend to reduce the destabilizing effects due to fluid rotation. Additional gains in stability for fixed geometry bearings are realized by altering the circular geometry. This is achieved by using preloaded lobes, lemon shaped or elliptical bearings, and offset half bearings. Some of these bearing geometries introduce significant asymmetry. The asymmetry in the bearings generally tends to enhance stability. Tripp and Murphy [5] have shown how asymmetry combines with the crosscoupled stiffness coefficients to influence the total energy added to the dynamic system. As is true with most engineering applications, there is a penalty associated with this approach. Asymmetry, which tends to reduce the destabilizing influence of crosscoupling, results in higher vibration amplitudes along the axis with the lower stiffness. This approach might also cause a split critical reducing the safe operating speed range of the machine. Furthermore, a fixed geometry bearing design that enhances stability for a certain load condition may be more destabilizing when subjected to a change in the load

direction or magnitude. Fixed geometry sleeve bearings are also very sensitive to changes in the running clearance.

#### Tilting Pad Bearings

Variable geometry tilting pad bearings are characterized by the inherent stability that arises from the low or negligible crosscoupling present in these bearings. The pads pivot and rotate in response to the load applied by the journal, and always produce a symmetric reaction force on the journal. The attitude angle is zero, provided the pad's inertia and pivot friction are neglected. Tilt pad bearings are therefore inherently stable because they provide negligible crosscoupling. However, the damping in tilting pad bearings can be lower and therefore insufficient to counter other destabilizing influences present in the machine. The bearings in some cases may be close to a node and provide very little damping for a certain mode. A schematic representation is shown in Figure 3 of the crosscoupled stiffness and damping forces present in a typical rotating machine. This representation shows graphically that the crosscoupled stiffness force acts in a direction opposite to damping. This is the reason why it is often referred to as negative damping. It is the balance of these two forces that determines whether or not a machine is stable. Every attempt at stabilizing a rotating machine ultimately either reduces the magnitude of the crosscoupled force, adds damping, or tends to accomplish both.

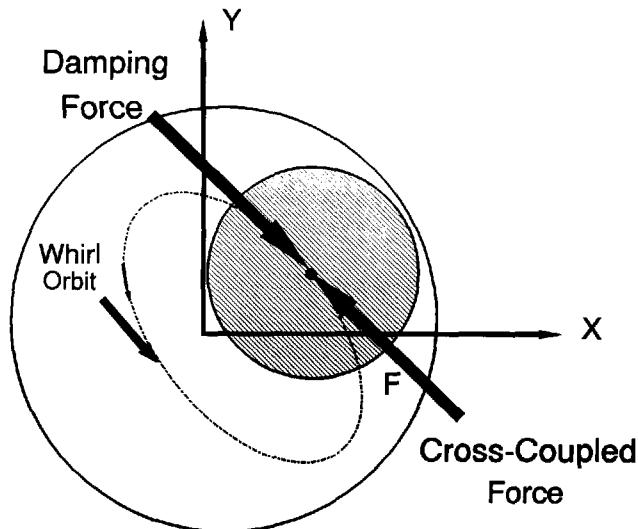

Figure 3. Crosscoupled Stiffness and Damping Force.

#### Squeeze Film Damper Bearings

Squeeze film dampers are often used to increase the damping and provide an optimum bearing support. When applied to process-type compressors, the squeeze film damper is generally used in series with a tilting pad bearing. A schematic presentation of such a configuration is shown in Figure 4. The O-ring support is often used for its convenience as a retrofit, and serves multiple purposes. It provides sealing, and thus improves the damping capacity of the damper by making it operate closer to the Reynolds long bearing model. This maximizes the damping from the typically limited axial space. The O-rings also help center the bearing within the squeeze film clearance, in addition to providing hysteretic damping. The lower equivalent stiffness, resulting from the tilt pad squeeze film damper combination, increases the shaft motion at the bearing supports and thus results in more effective damping.

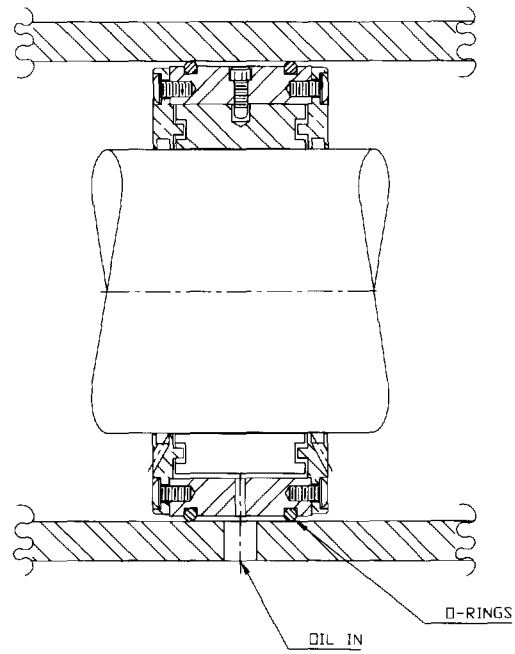

Figure 4. Combination Tilt Pad Bearing and O-Ring Supported Squeeze Film Damper.

The damper may also introduce asymmetry in the support, which also tends to enhance stability.

#### Floating Oil Film Seals

Oil film seals are used to provide controlled leakage of process gas in centrifugal compressors. The inner seal or gas side seal generally has a very small pressure differential in the range of 10 to 20 psi. The outer seal or atmospheric seal will generally have a much higher pressure drop. Oil film seals have been identified as being one of the causes of subsynchronous vibrations in centrifugal compressors. The compressors in these cases will generally be stable after the seals have undergone overhaul or maintenance. However, the vibration characteristics will deteriorate gradually with time as the seals wear, thus increasing the friction between the floating seal and housing. This eventually leads to locked up seals. Seal lockup can lead to unloading of the bearings and eventually to higher crosscoupling originating in the seals. The subsynchronous vibration frequency with oil film seals has been noted to be generally higher than the predicted natural frequency of the rotor bearing system excluding the seal. This is because the seals in a locked up position tend to increase the stiffness and raise the first natural frequency. The problems associated with locked up floating seals are often alleviated through better balancing of the axial forces on the seals. The contact areas between the seal and the housing are reduced and hardened to lessen the magnitude of the friction force and wear. Reducing the effective length of the seal and increasing the clearance are also some of the means used to reduce the crosscoupling effects in the event the seals lockup.

Kanki, et al. [6], introduced a modification to the floating seal which takes advantage of its squeeze motion. Maintaining a small gap between the seal OD and the housing mimics a squeeze film damper configuration. The location of the seals inward from the bearings makes the damping more effective for such a configuration. Vibration run up data reported by Kanki, et al. [6], clearly demonstrates the effectiveness of this arrangement particularly in suppressing the synchronous response.

### Impeller Forces

Aerodynamic excitations in high pressure centrifugal compressors are another source of vibrations in rotating machinery. Aerodynamic excitation and impeller forces are generally more complex and less amenable to quantitative analysis. The vibrations generated by impeller forces can be forced or self excited. The destabilizing forces are also generally larger with higher pressure and higher density fluids. Alford [7] provided a model to estimate the crosscoupling force present as a result of gap variation at the tip of the impeller. Wachel [8], introduced an empirical equation which has been widely used to model the crosscoupled forces in impellers.

### Labyrinth Seals

Labyrinth seals are used in turbines and compressors to reduce and control leakage. They are utilized for interstage seals, impeller eye seals, blade tip seals, and for sealing balance piston cavities. Labyrinth seals have been identified as a source of aerodynamic excitation contributing to rotordynamic instability problems in high pressure compressors. The gas flow through a labyrinth seal can be characterized by the two flow models shown in the schematic representation of Figure 5 from Elrod [9]. The gap or cavity flow dominates at the first few cavities of a labyrinth, while the corkscrew flow which is mostly circumferential is predominant away from the entrance of the seal. It is this circumferential flow which causes higher crosscoupling and stability problems in seals. Varying the circular geometry of a seal in a similar manner to lobed bearings is not a viable alternative. Therefore, the efforts to stabilize seals have concentrated on reducing the fluid circulation and increasing the direct damping.

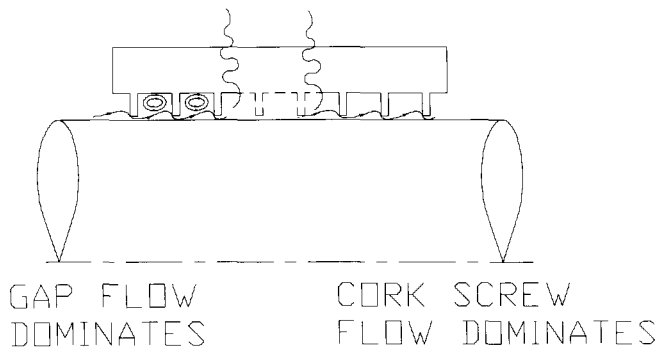

Figure 5. Flow in a Labryinth Seal.

There are several proven techniques utilized to reduce the destabilizing influence of labyrinth seals. Swirl brakes are often used to reduce the tangential velocity by straightening the flow as the fluid enters the seal. This approach was used on the impeller eye seals for the first case presented here. Bleeding gas from a higher pressure section of the compressor into the seal section to reduce fluid rotation is another approach that was also used in the first case. This is shown schematically in Figure 6. In this approach the gas is injected in a direction opposite to the shaft rotation. Zhou [10] was successful in utilizing this approach to cure the subsynchronous vibration problem on a low pressure compressor. Replacing labyrinth seals with honeycomb seals is yet another means of increasing stability in a compressor. Honeycomb seals have very low cross coupling and higher direct damping. Both of these characteristics are favorable for increasing stability. Using a honeycomb seal at the balance piston was the approach utilized in each of the cases presented in this paper. This single modification had the major influence in curing the stability problems.

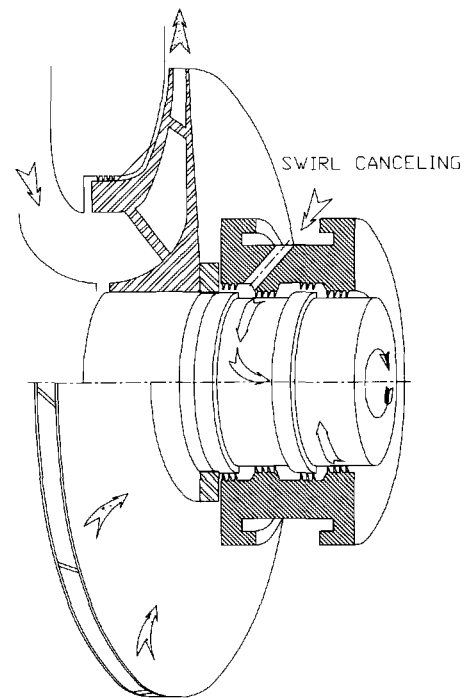

Figure 6. Swirl Canceling Device.

## CASE 1: BACK TO BACK COMPRESSOR

### Background

The first case describes the vibration instability experienced on a natural gas centrifugal compressor on an offshore platform. An aircraft derivative gas turbine with a power turbine drives the compressor over 10,000 rpm through a gear box. This compressor, when originally installed in 1976, had two compressor wheels mounted on the shaft in a straight through configuration. The rotor was supported on five pad tilt pad bearings with a load on pad (LOP) configuration. Sealing was maintained using floating oil film seals. In response to operational requirements, the number of impellers was increased to six by 1985. The impellers were arranged in two sets or stages, each consisting of three impellers. The two stages were arranged in a back-to-back configuration. The mid section of the rotor contained a two segment stepped interstage labyrinth seal (balance piston). Each segment of the labyrinth seal is approximately 4.0 in long. Due to stability problems, one of the balance piston seal segments was removed. A schematic of the rotor configuration before and after this modification is shown in Figure 7. This modification was made in order to minimize the destabilizing effects attributed to the labyrinth seals. The bearings were also changed to a load between pad (LBP) configuration. In mid 1985, dry gas seals were installed primarily due to problems caused by seal oil contamination. The stability was good after start-up, but became unacceptable after a compressor surge. A waterfall plot reproduced from Kocur, et al. [11], shows that the subsynchronous component appears at 48 to 49 percent of the running speed component. In November 1985, the bearing preload was reduced by increasing the assembly clearance. The bearing damping was further increased in July 1986 by increasing the pad length from 2.0 to 2.75 in. Both bearing changes temporarily improved stability until another compressor surge occurred. Swirl brakes were designed for the purpose of further enhancing the stability of the compressor. The swirl brakes were installed at the impeller eye seals in September 1987. Their influence was not

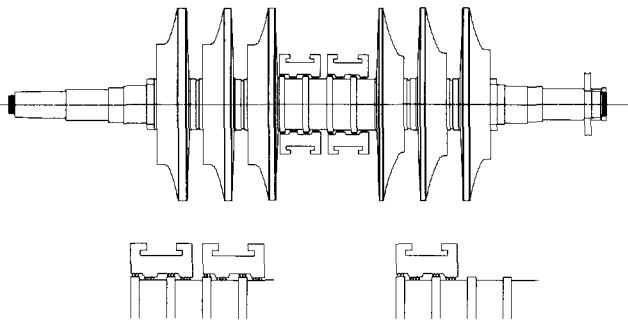

Figure 7. Balance Piston Labyrinth Initial Modification.

sufficient to make an impact on the stability of the compressor. The dry gas seals were removed from the compressor due to the higher subsynchronous vibrations which were not as pronounced with the floating oil film seals. In 1989, squeeze film damper bearings in series with the tilt pad bearings were installed to further improve the stability characteristics of the compressor.

The modifications described above all improved the vibration characteristics of the compressor to some degree. However, the performance and reliability was still below the desired level. A frequency spectrum of the compressor with the squeeze film damper bearings and floating oil film seals is shown in Figure 8. The subsynchronous vibration continued to be present in the frequency spectra, but remained bounded.

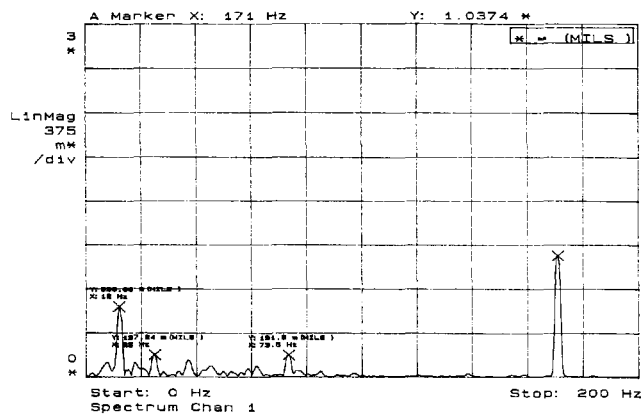

Figure 8. Subynchronous Vibrations with Combination Tilt Pad Bearing and Squeeze Film Damper.

#### Reevaluation of Stability for Dry Gas Seals Conversion

Although the compressor stability characteristics improved with the squeeze film damper and floating oil seals, occasional high subsynchronous vibrations, seal lockup, and wear of the oil seals continued to present a problem. Frequent maintenance was required due to excessive wear at the seal ring and housing interface. A cross sectional drawing is shown in Figure 9 of the floating oil seal housing. The wear on the seal land is shown in Figure 10 and a closeup of the same ring is presented in Figure 11, clearly defining the impingement and wear in the contact area. The excessive wear at the seal ring and housing interfaces made it necessary to reexamine the possibility of using the replacement dry gas seals. Furthermore, the contamination problem which was the main reason for the first attempt to convert to dry gas seals continued to be a driving factor.

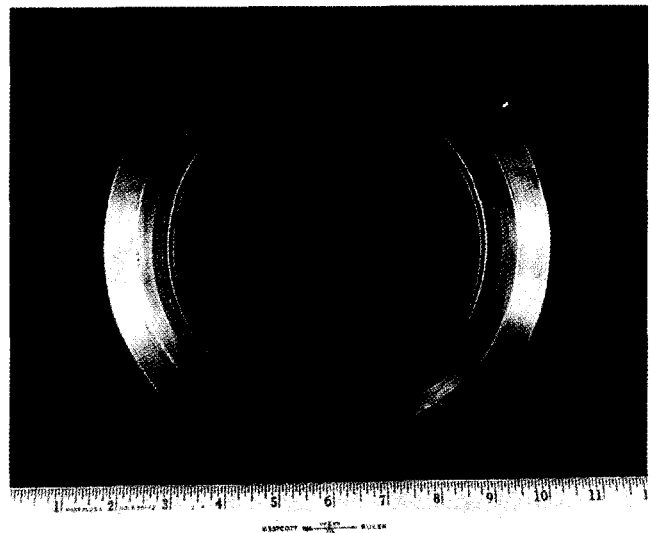
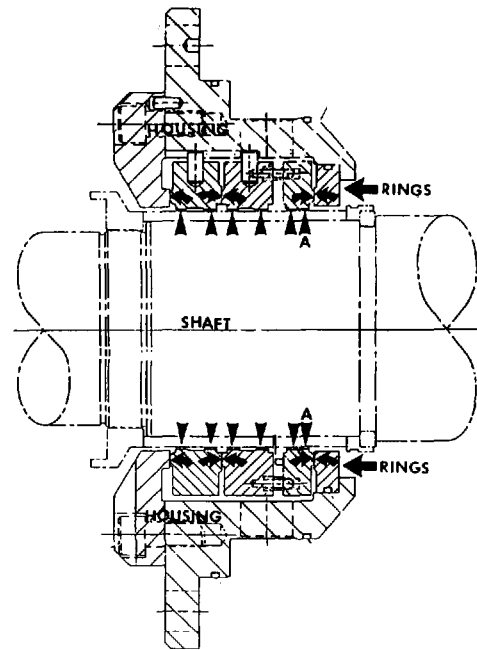

Figure 10. Fretting and Wear Damage on the Oil Film Seal Ring.

#### Friction Damping Effects of Floating Seals

The effects of floating oil film seals on rotor stability has traditionally been handled by assuming that the oil film seals are either floating or locked up at some eccentric or centered position. When the seals are assumed floating, their effects on stability are neglected. Although this assumption is generally considered conservative, the same is not true when the compressor stability is being evaluated for the removal of the seals. When the seals are floating, they provide a source of friction damping which is very effective due to their location inboard of the bearings where there is significant shaft motion. Their replacement with dry gas seals will remove this source of effective damping. Removing a stabilizing source of damping from the machine and not accounting for that loss in the model cannot result in a conservative estimate. The

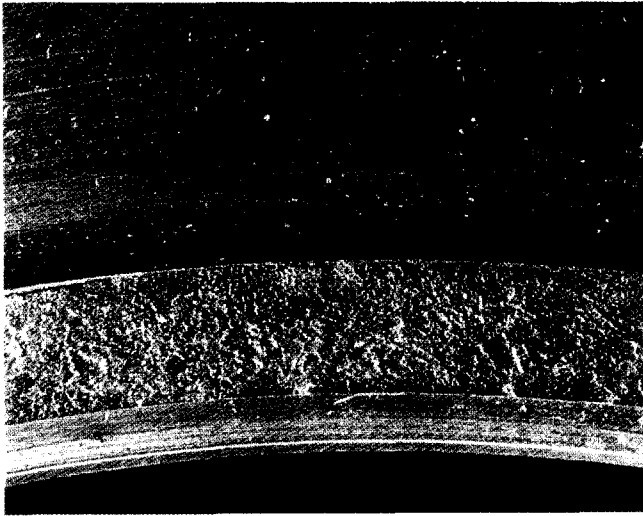

Figure 11. Closeup View of the Floating Oil Seal Ring.

loss of friction damping available from the oil film seals when they are floating must be accounted for. Otherwise, another damping source should be added to the system to make up for the loss of friction damping provided by the seals. This is particularly important for marginally stable machines like the ones discussed here.

The loss of friction damping provided by the oil film seals must be compensated for when replacing them with dry gas seals. This is because dry gas seals are not known to generate any significant damping. The first unsuccessful attempt at a conversion was a constant reminder of how critical such an operation can be. The present analysis includes an estimate of the friction damping provided by the oil film seals as they float and slide against the mating seal housing. This provides a qualitative estimate of the minimum additional damping required to compensate for the removal of the oil film seals. The influence of the oil film seals on stability is discussed later in the stability analysis section.

#### Rotordynamic Model Verification

The rotor model used in the analysis was confirmed through measurements made on a spare rotor. The computer model was verified through impact testing with the rotor suspended on flexible slings [12]. The first three free-free measured modes of the rotor matched the numerically predicted frequencies. This confirmed that the mass elastic properties for the rotor were adequately modelled. The rotor model used in this analysis is shown in Figure 12. The rotordynamic analysis program used is based on the polynomial transfer matrix method. The bearing location on the shaft is reflected by the spring elements, and are modelled as forces applied to the rotor. In the stability analyses, the oil film seals, labyrinth seals, and the squeeze film dampers, were also modelled as forces applied to the rotor.

#### Stability Analysis

The ultimate goal of this stability analysis was to again try to install the dry gas seals. It was very important to avoid the problems experienced on the first attempt. Since it was apparent that the oil film seals were providing a source of damping which was very critical to the stability of the compressor, it was essential to provide another source of damping to compensate for their removal. To get a feel for the stabilizing effects of the floating seals, the axial force was computed from a balance of the pressures in the seal cavities. The friction force was then computed and the friction damping converted to an equivalent viscous damping. The

BACK TO BACK COMPRESSOR ROTOR MODEL  
FYZ 11/19/90 DRY GAS SEALS  
Shaft Mass=1071.470 lbm Shaft Length=86.085 inches C.G.=40.793 inches

MATERIAL 1  
MATERIAL 2

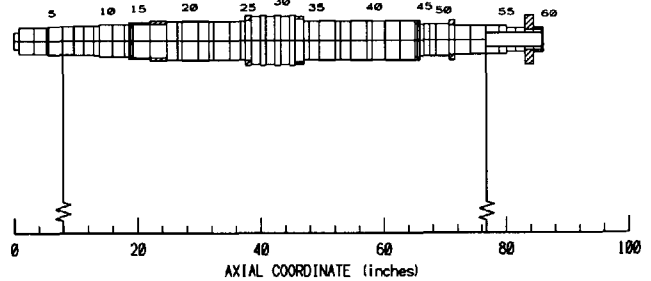

Figure 12. Back to Back Compressor Rotor Model.

stability was computed with and without the effect of the friction damping. The mode shape and the logarithmic decrement are shown in Figure 13 without the friction damping effects. The effect of adding the friction damping on the same model is shown in Figure 14. The logarithmic decrement increases from -0.6399 to 0.0941. This is a very significant effect and can explain the problems experienced during the first dry gas seal conversion attempt.

ROTOR DYNAMIC MODE SHAPE PLOT  
BACK TO BACK COMPRESSOR STABILITY ANALYSIS  
DAMPER & STEPPED BALL PISTON LABY WITHOUT OIL SEALS FRICTION DAMPING EFFECT  
SHAFT SPEED = 11000.0 rpm  
NAT FREQUENCY = 2585.86 cpm LOG DEC = -0.6399  
STATION 27 ORBIT FORWARD PRECESSION

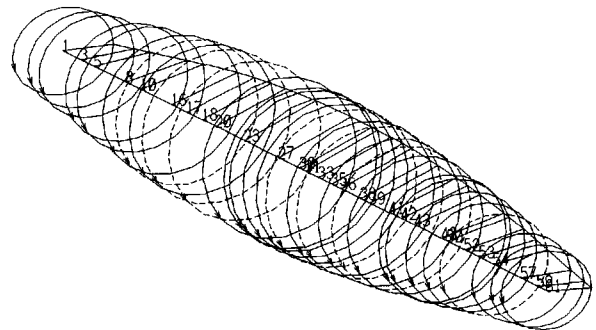

Figure 13. First Forward Mode Neglecting the Effects of Friction Damping.

After the first conversion to dry gas seals, the subsynchronous vibrations experienced on the compressor after a surge pointed to the labyrinth seals as a likely source of instability. The labyrinth seal clearance opened up significantly after surging, due to excessive rotor excursions. This resulted in more fluid rotation and less gap flow leading to higher crosscoupling and consequently higher subsynchronous vibrations. The replacement of the labyrinth seals with honeycomb seals, and the added benefit of replacing a destabilizing source with a more stabilizing element, were expected to provide the best combination for increased stability.

Stability predictions for high pressure centrifugal compressors are very difficult, and are often missed as evident by the many case histories published in the literature. This difficulty stems from the fact that the aerodynamic excitations present in the impellers and

ROTORDYNAMIC MODE SHAPE PLOT  
 BACK TO BACK COMPRESSOR STABILITY ANALYSIS  
 DAMPER AND STEPPED BAL. PISTON LABY W/OIL SEALS FRICTION DAMPING EFFECT  
 SHAFT SPEED = 11000.0 rpm  
 NAT FREQUENCY = 2553.46 cpm, LOG DEC = 0.0941  
 STATION 27 ORBIT FORWARD PRECESSION

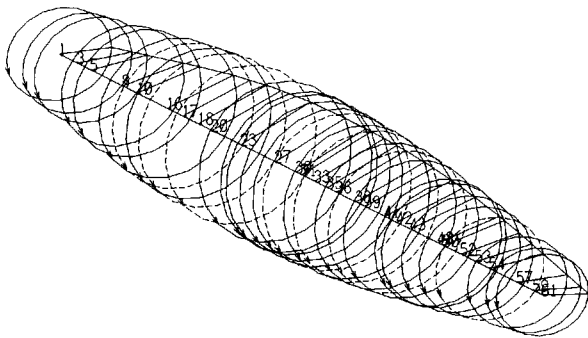

Figure 14. First Forward Mode Including the Effects of Friction Damping.

seals are much more difficult to predict than the dynamic coefficients for fluid film bearings. Field measurements were used to determine an approximate value for the crosscoupling present in the impellers. The crosscoupling coefficients were increased until a negative logarithmic decrement was predicted for the first forward mode. This exercise simulated the conditions present when the dry gas seals were first installed in the compressor. The first natural frequency and associated forward mode shape are shown in Figure 15. These predictions matched well with the measured subsynchronous frequency experienced in the field and reproduced in Figure 16 [11].

ROTORDYNAMIC MODE SHAPE PLOT  
 BACK TO BACK COMPRESSOR STABILITY ANALYSIS  
 DRY GAS SEALS AND STEPPED BAL. PISTON LABY  
 SHAFT SPEED = 11000.0 rpm  
 NAT FREQUENCY = 3489.49 cpm, LOG DEC = -0.0947  
 STATION 30 ORBIT FORWARD PRECESSION

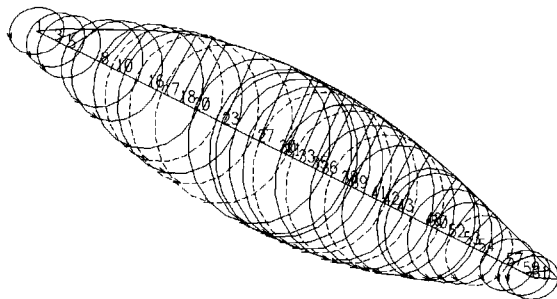

Figure 15. Stability Analysis with Dry Gas Seals and Balance Piston Labyrinth Seal.

The first unsuccessful attempt to convert to dry gas seals initially forced the examination of alternative modifications which could be readily reversed. This was the reason a stepped honeycomb seal configuration was looked at as the primary alternative to replace the existing labyrinth seal segment. Childs [13] was consulted to provide stiffness and damping coefficients for a replacement honeycomb seal. The seal coefficients are shown in Table 1. A summary of the analysis conditions and the results are shown in Table 2. As expected, the analysis showed that the

Table 1. Honeycomb Dynamic Coefficients.

Config.	Diameter in	K lb/in	k lb/in	C lb-sec/in	K/cω
Stepped	7.81/8.19	28,000	5,300	48.4	0.11
Straight	8.19	5,000	26,000	405	0.05
Straight	7.81	5,000	24,600	380	0.05

Table 2. Summary of Stability Analysis.

Bearing	Bal. Piston	Seal	Log. Dec.
Damper	Laby	Oil Film	-0.6399
Damper	Laby	Oil Film*	0.0941
Tilt Pad	Laby	Dry Gas Seal	-0.0947
Damper	Honeycomb	Dry Gas Seal	2.4163

honeycomb seals would provide higher damping and lower cross-coupled stiffness coefficients. However, the analysis also showed that there is a distinct advantage in using a straight through honeycomb seal instead of the stepped honeycomb. The damping for a straight through configuration resulted in a significant increase in the direct damping. The increase was close to an order of magnitude larger than was available with the stepped honeycomb configuration. This result was too important to ignore, and it led to a reconsideration of the original modification criteria which mandated the modifications be readily reversible. This is because a straight honeycomb seal configuration would require machining the steps on the shaft, a modification that cannot be readily reversed.

The rotor was analyzed with the squeeze film damper bearings that were installed in series with the tilting pad bearings. The

TRAIN ID: K-101 COMPRESS.SET  
 MACHINE ID: COMPRESSOR  
 PROBE ID: COMP. THRST. END VERT  
 RUNUP  
 RUN: 2 DATE: 1-11-85 TIME: 0915 HRS

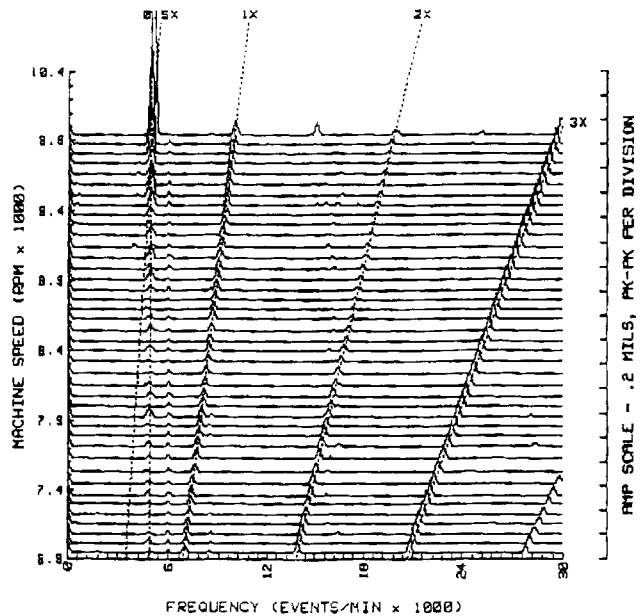

Figure 16. Subsynchronous Vibrations with Dry Gas Seals [11].

stiffness and damping coefficients for the squeeze film damper bearing were added in series to the speed dependent tilting pad bearing coefficients. The stability analysis included the labyrinth seals coefficients at the balance piston. This was done to establish the performance predicted under the existing conditions for use as a bench mark. This would also provide a relative evaluation of the beneficial effects of the damper bearings. The results with the labyrinth seals and the damper bearings are shown in Figure 14 for the first forward mode and in Figure 17 for the second forward mode. These two modes were more stable due to the effect of the squeeze film damper. It is important to note that the lower support stiffness of the squeeze film damper changed the modes and frequencies for the first two forward modes. Furthermore, the modes are closer to being rigid modes with the damper bearings. This was expected mainly due to the higher shaft stiffness relative to the stiffness of the bearing supports. Even though the logarithmic decrement for the first mode was slightly positive, field measurements revealed that the compressor continued to experience subsynchronous vibrations. This indicated that the model did not completely simulate the exact magnitudes of some of the sources of crosscoupling present in the compressor. The disagreement between the analytical predictions and field measurements could also be caused by the damper bottoming out. This can significantly reduce the effective damping available from the damper. It was therefore necessary to further maximize the value of the logarithmic decrement for the first mode in order to compensate for some of the unknown factors. The logarithmic decrement value of 0.0941 was therefore judged to be insufficient for this configuration based on the field measurements.

ROTORDYNAMIC MODE SHAPE PLOT  
BACK TO BACK COMPRESSOR STABILITY ANALYSIS  
DAMPER AND STEPPED BAL. PISTON LABY W/OIL SEALS FRICTION DAMPING EFFECT  
SHAFT SPEED = 11000.0 rpm  
NAT FREQUENCY = 3300.78 cpm, LOG DEC = 4.7605  
STATION 61 ORBIT BACKWARD PRECESSION

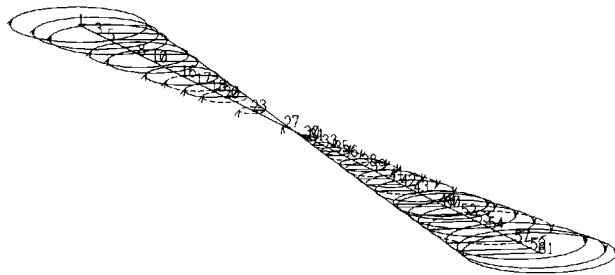

Figure 17. Second Forward Mode with Squeeze Film Damper and Oil Film Seals Friction Damping Effects.

The analysis for the straight through honeycomb configuration was based on the coefficients shown for the third set in Table 1. These correspond to the conditions under which the shaft diameter would be machined to 7.81 in. The stability analysis with the damper bearings and straight through honeycomb seals is shown in Figures 18 and 19. The most important difference is the significant increase in the logarithmic decrement for the first forward mode which is now critically damped. The improvement in stability is several times that predicted with the damper bearings and labyrinth seals.

#### Modifications and Resulting Vibration Characteristics

The conversion from oil film seals to dry gas seals was thought to have a much better chance of succeeding based on the results of the stability analysis shown above. It was recommended that the

ROTORDYNAMIC MODE SHAPE PLOT  
BACK TO BACK COMPRESSOR STABILITY ANALYSIS  
DAMPER & HONEYCOMB BAL. PISTON SEAL (STRAIGHT)  
SHAFT SPEED = 11000.0 rpm  
NAT FREQUENCY = 2160.02 cpm, LOG DEC = 2.4163  
STATION 1 ORBIT FORWARD PRECESSION

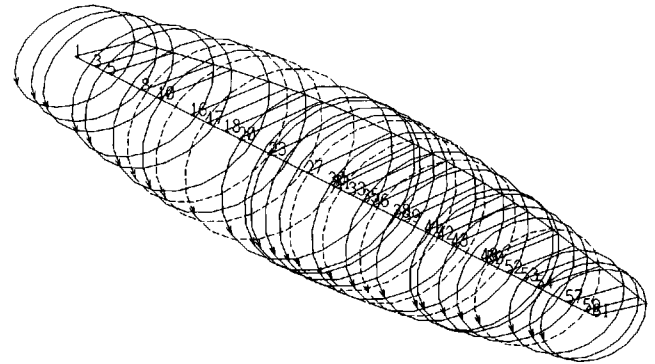

Figure 18. First Forward Mode with Straight Honeycomb Seal.

ROTORDYNAMIC MODE SHAPE PLOT  
BACK TO BACK COMPRESSOR STABILITY ANALYSIS  
DAMPER & HONEYCOMB BAL. PISTON SEAL (STRAIGHT)  
SHAFT SPEED = 11000.0 rpm  
NAT FREQUENCY = 4328.60 cpm, LOG DEC = 3.1226  
STATION 61 ORBIT FORWARD PRECESSION

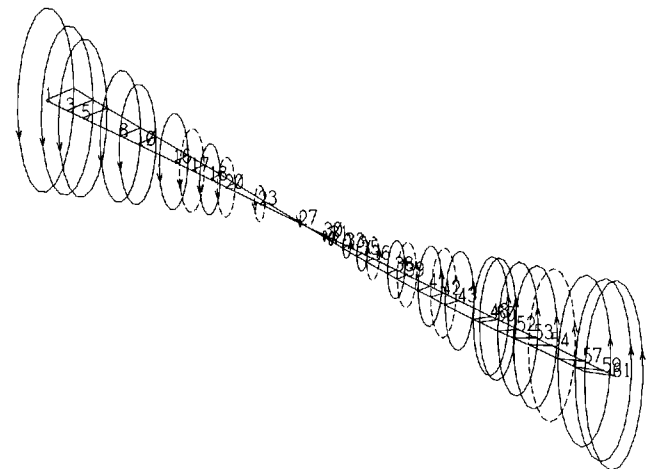

Figure 19. Second Forward Mode with Straight Honeycomb Seal.

conversion to dry gas seals be accompanied by a modification of the center seal section. The shaft was machined at the balance piston section to remove the stepped rotor configuration, and the labyrinth seals in the stator were replaced by a straight through honeycomb seal. The honeycomb cell size was 1/16 in and 0.080 in deep. The length of each seal segment was 4.22 in and both seal segments were installed in the compressor during this conversion. The seal configuration is shown in Figure 20 before and after the modification.

The compressor was started after the modifications and vibration data was recorded on August 18, 1991. The frequency spectrum shown in Figure 21 verifies the absence of any subsynchronous vibrations. The compressor has been on line for over two years with no problems and has operated more reliably than at any other time in the past.



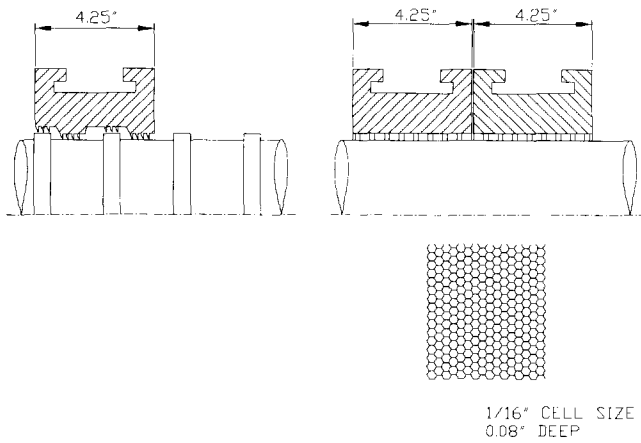

Figure 20. Balance Piston Modification from a Stepped Laby to a Straight Honeycomb.

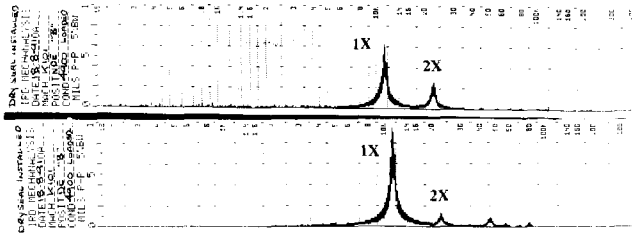

Figure 21. Vibration Frequency Spectrum after the Honeycomb Seal Modification.

Case 1 Conclusions

The modifications used to solve the stability problems on the back-to-back compressor case (case 1), provided significant insight into the various destabilizing components present in high pressure centrifugal compressors.

- This case showed that the oil film seals were playing a stabilizing role through the friction damping action they provided while floating. The first attempt to replace them with dry gas seals was enough to push the compressor beyond its stability limit.

- This case also showed that the bearings, which are usually among the most critical components in the machine and often the easiest and only modification required for stability, were not sufficient in this case to provide a stable operation. The modifications to the center seal (balance piston seal) were shown to be the most effective in increasing the stability of the compressor.

- The squeeze film damper bearings did improve the stability slightly, but in this case were not enough to completely counter the destabilizing forces present. The use of squeeze film dampers in series with fluid film bearings in process compressors have demonstrated mixed results. The elastomer O-rings used to center the bearing does not generally result in adequate performance, particularly when supporting relatively heavy rotors or loads. The damper often bottoms out under these conditions, and is not as effective in providing the desired damping.

- This case also shows that the dry gas seal conversion can be successful on existing machines, provided the stability of the compressor is closely scrutinized. On marginally stable machines, this conversion must also be accompanied by other modifications to further enhance the stability characteristics of the compressor.

- The back-to-back compressor configuration has traditionally been known to be susceptible to subsynchronous vibrations. This perception is based on several case studies which were widely reported in the literature. Such adverse field experience has severely affected their potential use, even though such a configuration has inherent operational and performance advantages. The understanding of the crosscoupling at the center seal sections, and the damping available with other seal configurations (honeycomb seals), can be used to advantage. This knowledge should allow the back-to-back compressor configuration to overcome the reservations many manufacturers and users have regarding their use. The new knowledge obtained from field experience and current research can be effectively utilized to design more efficient and reliable compressors with longer spans between bearings, taking advantage of the amount of effective damping provided by the seals.

- The use of negaswirl mechanisms should be investigated further to determine the conditions under which they are most effective. In this case the negaswirl device was not very effective. Zhou [10] used the negaswirl configuration to stabilize a low pressure centrifugal compressor. The results in the referenced compressor case were positive and produced a more stable operation.

- This case also showed the importance of labyrinth seal clearance on stability. After the compressor surged, there was a subsequent increase in the labyrinth seal clearance. This resulted in high subsynchronous vibrations which prevented the compressor from remaining online. The current theory does not appear adequate to fully predict the magnitude of the crosscoupled stiffness coefficients under these extreme clearance conditions.

CASE 2: FIVE STAGE STRAIGHT-THROUGH COMPRESSOR

Background

A 2800 hp, 10,200 rpm, fivestage hydrogen recycle compressor in a Gulf Coast refinery was operated with reasonable success for several years in the 7500-9500 rpm speed range. The turbine driven compressor is configured in a straight through arrangement as shown in Figure 22. Higher unit charge rates required higher flow from the recycle compressor and continuous operation near 10,000 rpm. Although the compressor design speed was 11,000 rpm, the unit experienced excessive subsynchronous vibration levels at the higher speeds. The high vibration levels resulted in shaft end oil seal failures. This limited the speed range, and thus the compressor flowrates. Detailed field vibration measurements were made and a comprehensive rotordynamics analysis was initiated to characterize the problem and develop a solution.

It was concluded from the analysis and field testing that a subsynchronous instability problem was responsible for the high vibration levels. The cause of the instability was believed to be high crosscoupled stiffness values resulting from oil seal lockup.

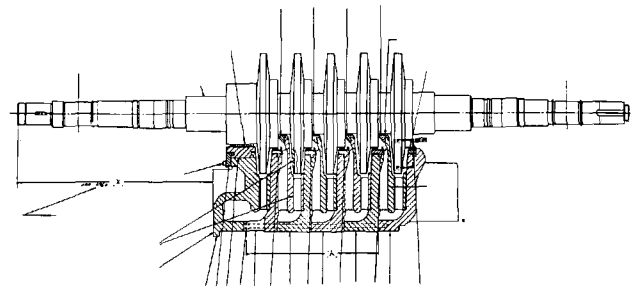

Figure 22. Schematic of the Straight Through Compressor.

To eliminate these effects, gas seals were installed as described by Atkins and Perez [14]. The rotordynamic modelling and analysis indicated an adequate logarithmic decrement (log dec) for the unstable mode could be realized with dry gas seals. Baseline vibration data gathered after startup with the gas seals showed no significant subsynchronous components. It was felt that the use of gas seals resulted in a significant improvement in the rotor stability.

Compressor fouling, and the subsequent increase in rotor imbalance, dictated a change of the compressor's rotor during the coming planned unit outage. This coincided with a year of operation since the dry gas seal conversion. Inspection of the rotor revealed the heavy fouling suspected to be present on the impellers. A spare rotor was installed in the compressor to replace the fouled rotor. The initial startup of the compressor with the spare rotor did not reveal any presence of subsynchronous vibration components. During the latter stages of the plant startup, several operational problems were encountered. As a result of these problems, the compressor experienced severe surge on several occasions. Each surge cycle was sustained for an extended time. During these surge conditions, subsynchronous vibration was noted to grow to unacceptable levels. Vibration levels exceeded 10 mils at a frequency of 4500 cpm while the running speed was increased to approximately 10,000 rpm. The subsynchronous vibration amplitude represented 90 percent of the total vibration amplitude as shown in Figure 23. Acceptable vibration amplitudes could only be reestablished by reducing the speed below the first lateral critical speed. This forced a compressor and plant shutdown.

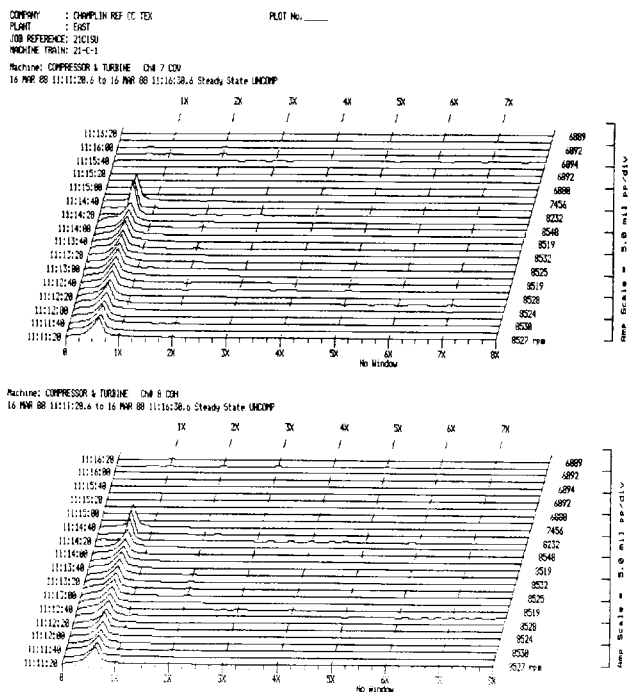

Figure 23. Cascade Spectrum Showing High Subsynchronous Vibration.

After these vibration excursions, the five pad load on pad (LOP) tilt pad bearings were removed for inspection. Some bearing shoes were locked, and the bearing wear pattern indicated the shoes were misaligned relative to the rotor journals. The bearing inspection also revealed that the assembly clearance was 5.0 mils diametral. This corresponded to the minimum clearance specified by the manufacturer.

The tight bearing clearance and the locked pads were both thought of as contributors to the reduced stability margin. The most expedient course of action available to get the machine back online was to install a set of spare bearings. These bearings were found to have 5.0 to 5.5 mils diametral clearance. During the installation of the bearings, great care was taken to ensure proper bearing alignment. After starting with the spare bearings, the compressor again experienced subsynchronous vibrations with amplitudes exceeding 5.0 mils. Internal damage to interstage and balance piston labyrinths was suspected as being the primary contributor to the subsynchronous vibrations. This was further supported by the fact that compressor efficiency was low, rotor axial position was significantly different than normal, and the thrust bearing metal temperatures were high.

The high subsynchronous vibrations necessitated reducing the machine speed to maintain the vibration amplitudes within acceptable limits. The rotordynamic model and analysis from the previous gas seal retrofit project was revisited to evaluate potential modifications for further improvements to the rotor stability.

#### Stability Analysis

The stability model included the tilt pad bearings, the interstage labyrinth seals, the balance piston labyrinth, as well as aerodynamic crosscoupling at the impellers. For nominal values of bearing and labyrinth seal clearance, the system log dec ( $\delta$ ) at the rated speed of 10,000 rpm was predicted to be 0.24. Because of the surge event, it was felt that excessive interstage and balance piston seal clearances were likely. The computer model was used to predict the effects of labyrinth seal clearance of double their nominal values. Although the system logarithmic decrement reduced slightly to 0.23, it was still considered sufficient to provide a stable rotor system.

Some computer simulations investigated an arbitrarily high value for aerodynamic crosscoupling of 40,000 lb/in. This was found to be the level sufficient to drive the rotor unstable. The crosscoupling was much higher than the originally predicted value of 740 lb/in using the Wachel equation. Since the recycle gas in the compressor was relatively light, the only feasible means of generating this level of aerodynamic crosscoupling was thought to be the unexpectedly high labyrinth seal clearance which was three times greater than nominal recommended clearance. The other possible actor which has the potential of producing high crosscoupling is excessive impeller clearance eccentricity.

The compressor thermodynamic performance data showed that the machine was operating at much lower efficiency levels. This pointed to the possibility of high labyrinth seal leakage as the most probable cause for the vibrations. Due to the pressing production requirements, and a lack of additional spare parts, the stability analysis was limited to selecting an optimum bearing to replace the damaged bearing. The plan was to run at reduced throughput until an extended outage could be scheduled.

The stability analysis showed that the maximum clearance, minimum preload bearings resulted in the best rotor stability as shown in Table 3. A third party bearing vendor was used to supply the bearings due to time constraints. The upper end of the compressor manufacturer's clearance range was chosen, and bearings with 0.2 pre-load and 7.0 mils diametral clearance were manufactured. Although the analysis showed better stability with the 8.0 mils set clearance, the fear that manufacturing tolerances could result in a negative preload favored the tighter bearing clearance of 7.0 mils. The pertinent rotor-bearing system parameters are summarized in Table 3.

#### Rotor Operating with 7.0 Mil Bearing Clearance

The compressor was retro-fitted with a self-aligning, ball and socket, five pad tilting shoe bearing. Bearing clearances were

Table 3. Rotor-Bearing System Parameters.

Assembled Diametral Clearance (Inches)	Pre-load	Kxx lb/in	Kyy lb/in	Cxx lb-sec/in	Kyy lb-sec/in	Log Dec $\delta$
0.005	0.5	$2.85 \times 10^5$	$3.79 \times 10^5$	286.4	335.5	.203
0.007	0.2	$8.35 \times 10^4$	$2.25 \times 10^5$	132.3	221.4	.325
0.008	0.2	$4.93 \times 10^4$	$2.11 \times 10^5$	98.8	205.4	.334

Total Rotor Weight = 500 lbs  
 Rotor Length = 63.88 inches  
 Pad Length = 1.375 inches  
 Bearing Type - 5 Shoe Load-on-Pad  
 Bearing Coefficients at 10,000 rpm

Bearing Span = 54.72 inches  
 Shaft Diameter = 2.9995 inches  
 Oil Viscosity =  $2 \times 10^{-6}$  Reyns

opened to 7.0 mils diametral and the pad bore was modified to achieve a 0.2 preload. After startup, the subsynchronous peak was still present as the running speed approached 9000 rpm. The stability margin appeared to be slightly better, but was still unacceptable as shown in Figure 24. Since the stability predictions did not match the observed field vibrations, it was suspected that internal damage to the compressor could account for the apparently high destabilizing forces. A plot of the subsynchronous vibration component is shown in Figure 25 as a function of the differential pressure across the compressor ( $\Delta P$ ). Although the subsynchronous vibration levels were relatively low (< 2 mils, pk-pk), maintaining it within a bounded range forced operations to limit the rotor speed to about 8700 rpm. This sensitivity to the pressure differential across the compressor suggested that the effective destabilizing forces were greater than anticipated.

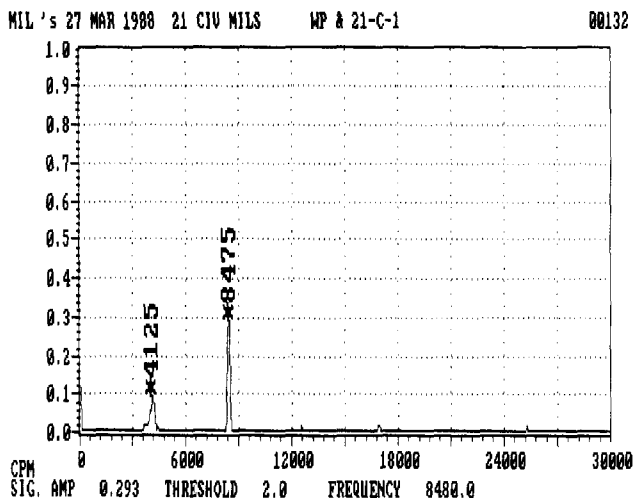

Figure 24. Vibration Spectrum with the 7.0 Mil Bearing Clearance.

Scheduled Outage Plan

The unit continued to operate at reduced speed and throughput until the next scheduled outage. The lower compressor throughput added more pressure towards ensuring that an optimum solution and a sure fix be planned for the next available opportunity. Discussion and brainstorming sessions led to five key considerations, and they are as follows:

- **Rotor Replacement:** The compressor experienced subsynchronous vibrations after the original heavily fouled rotor was replaced with the spare rotor. The difference in the performance of the two rotors raised questions as to whether the two rotors could have different levels of internal hysteretic damping. Installing the

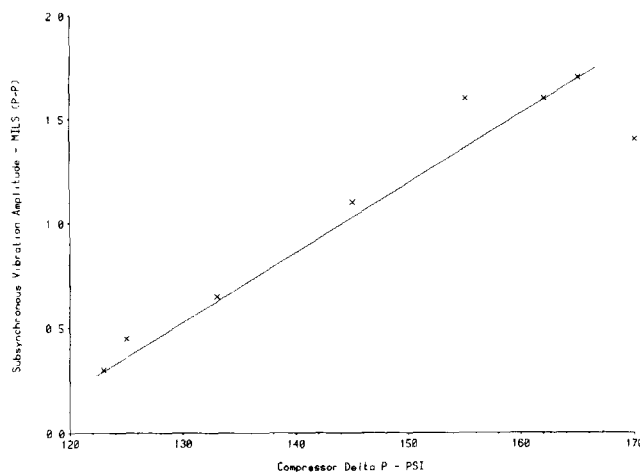

Figure 25. Hydrogen Recycle Compressor Plot of Subsynchronous Vibration Amplitude Vs Pressure Rise.

original rotor was considered as a means of eliminating that possibility, since it was difficult to determine otherwise. This was also desirable from a scheduling standpoint, since the original rotor was stacked and ready for operation.

- **Additional Bearing Optimization:** Calculations were made to see if any further stability improvements could be realized through bearing design changes. Various designs were considered, which included four shoe load on pad (LOP) and five shoe load between pads (LBP). The five shoe LOP design was found to be the best from a stability standpoint. Discussions with the manufacturer led to a further increase in the maximum clearance to eight mils diametral with a 0.2 preload. This was predicted to provide a slight improvement over the seven mils bearing clearance.

- **Oil Film Seal Effects:** Oil film seals have been thought to provide damping and, in some cases, improve stability [14]. This is true when the seals are operating properly and floating. Too often, the seals lockup and produce destabilizing crosscoupling components which overcome the stabilizing influence they provide. Consequently, the gas seals were preferable from a stability standpoint.

- **Additional Testing and Verification:** The original rotor was scheduled to be completely disassembled, re-stacked, and high speed balanced in preparation for the outage. It was felt that perturbation testing to determine the "mechanical" logarithmic decrement  $\delta_m$  (excluding seal and impeller aerodynamic effects) would be useful as a bench mark in assessing rotor stability. Perturbation tests have been discussed in the literature [15, 16] and have provided insight into rotor-bearing system dynamic behavior. Perturbation testing conducted at a high speed balancing facility [16] was found helpful in the determination of the optimum bearing clearance in terms of system damping.

- **Evaluate the Potential Benefits of Honeycomb Seals:** Based on a recommendation by Dr. Dara Childs (Texas A&M University), a honeycomb balance piston seal design was considered as a means of reducing crosscoupling seal effects while maximizing seal damping coefficients. Rotordynamic benefits of honeycomb seals are not widely known in the refinery industry. The honeycomb seal dynamic coefficients were provided by Childs. These coefficients were used in evaluating the rotordynamic stability characteristics of the compressor. The analysis predicted higher stability with the honeycomb seal and optimized bearings. The added stability benefits with honeycomb seals along with the more

rugged performance they have shown in other field installation made the option to use them more desirable.

#### Stability Characteristics of Honeycomb Versus Labyrinth Seals

Different balance piston seal configurations were analyzed as a means for predicting the relative stability improvements. The results are shown in Table 4 along with the calculated natural frequency corresponding to the first forward mode. The associated logarithmic decrements ( $\log_{10} \delta$ ) and the whirl frequency ratios ( $k_{xy}/C\omega$ ) are also presented for each of the configurations analyzed.

Table 4. Summary of Balance Piston Effects w/7 Mils Bearing Clearance, 0.2 Preload.

Configuration	CL Mils	Natural Frequency CPM	Log Dec $\delta$	$K_{xy}/C\omega$	$K_{xy}$ lb/in	C lb- sec in
W/out Balance Piston	-	3290	0.39	-	-	-
Original Balance Piston	11.0	3091	0.42	1.6	11600	6.5
Design	22.0	3074	0.41	1.3	16700	11.4
Honeycomb Stator	9.0	3781	1.72	0.08	20700	236
Smooth Rotor	12.0	3600	1.31	0.07	12200	152
Honeycomb Stator	3.0	3171	0.47	0.70	7600	9.7
Labyrinth	6.0	3185	0.46	0.83	9200	9.9
Rotor	9.0	3195	0.46	0.95	11000	10.3
	12.0	3202	0.45	1.09	13100	10.7

The results clearly show that a honeycomb seal stator with a smooth rotor offers a higher logarithmic decrement. Of the two honeycomb stator/smooth rotor clearance options considered, the tighter clearance of 0.009 in produced the highest calculated log dec of 1.72. This is a significant improvement over the log dec of 0.42 predicted with the labyrinth seal configuration. The whirl frequency ratio ( $k_{xy}/C\omega$ ) was also found to be lower for the honeycomb seal configuration, indicating that this option provided low crosscoupling effects and significant direct damping.

#### Additional Advantages of Honeycomb Seals

The rotordynamic benefits of the honeycomb seal were augmented by the fact that the seal had several mechanical advantages:

- Nelson [17], along with other users, has found that a honeycomb balance piston can reduce leakage by as much as 60 percent and in most cases, result in a lower thrust load.
- Honeycomb seals are more forgiving in the event of a rotor-stator rub. One and a half years after the installation of the honeycomb seal, the compressor experienced a severe surge. After this event, the compressor did not show any signs of instability. Later inspection during an overhaul revealed only minor rub damage on the honeycomb seal.
- The variety of honeycomb seal alloys available offers a greater range of applications in corrosive gas environments.
- Honeycomb seals are capable of sustaining higher temperatures. This presents an advantage over conventional labyrinth seals which are prone to fail at high compressor discharge temperatures.

#### Results After Honeycomb Seal Retrofit

Because of the overwhelming advantages the honeycomb seal provides over conventional labyrinth seal configurations, it was installed along with the optimized bearings. The interstage labyrinth seals were also found to be at two to three times the normal clearance and were replaced during the planned turnaround. Subsequently, the compressor started up and operated uneventfully. After three years of operation with the honeycomb seals, the compressor has not been shut down due to subsynchronous vibration. A typical spectral plot that is representative of the overall performance of the compressor since the honeycomb seal conversion is shown in Figure 26. Even though the compressor has surged during this period and the seal was subjected to wear, there has been no sign of any subsynchronous frequency components. To date, operations has been pleased with the performance and reliability of the compressor after the honeycomb seal conversion. The maintenance department is now considering the use of honeycomb balance piston seals in all future compressor upgrades.

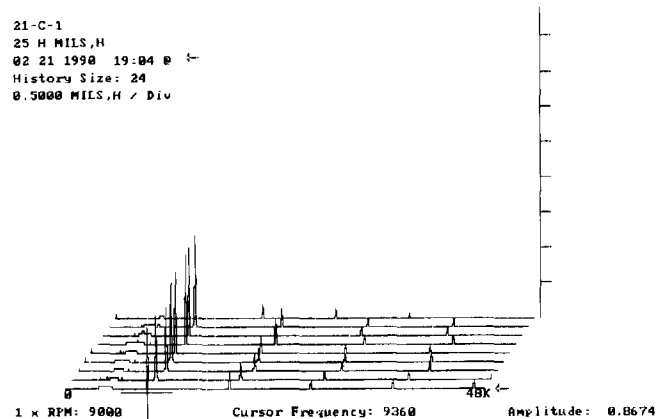

Figure 26. Vibration Spectrum with Honeycomb Seals.

#### Case 2 Conclusions

- The honeycomb seal (rough stator), running against a smooth balance piston journal (smooth rotor), provided the greatest margin of stability among all of the seal configurations considered.
- The honeycomb seal has shown to be relatively inexpensive, rugged, and energy efficient.
- It is not always possible to operate centrifugal compressors under ideal conditions. There will always be instances where the compressor operates at undesirable operating conditions. These conditions could result in surge, rub, and subsequent increase in the seal clearances. These conditions, as was shown here, may lead to high subsynchronous vibrations. The honeycomb seal has proven to be insensitive to these events and conditions. Designers are encouraged to incorporate such elements in the design of new machinery.

#### GENERAL CONCLUSIONS

- In the two cases discussed, the compressors were marginally stable. The conversion to dry gas seals eliminated a source of friction damping provided by the floating of the oil film seals. The use of honeycomb seals, which replaced the labyrinth seals on the balance piston section, was the most significant modification and contributed the most to the stability of each of the compressors.
- Field experience with the two compressors revealed that the labyrinth balance piston seals were wiped when the compressor

surged. The excessive clearance at the labyrinth seals after the surge resulted in excessive subsynchronous vibrations in both cases. The analytical simulations for the labyrinth seals with excessive clearance fell short of predicting the actual magnitudes of the destabilizing crosscoupling experienced in the field. This suggests that the existing analytical tools are not capable of adequately modelling labyrinth seals with excessive clearances. The honeycomb seals on the other hand has proven to be more rugged and less sensitive to the opening of the clearances after a surge.

- Although the dry gas seals in both cases did not in themselves cause the stability problems experienced, they did replace the oil film seals which were to some extent masking out the destabilizing forces present in the compressor. Oil film seals have caused problems in many high speed compressors, and are generally regarded as a potentially destabilizing component. This is particularly true when they lockup. The two cases presented here showed some of the positive damping influence present in these floating seals when they are functioning properly. This effect is often ignored and unaccounted for by most rotordynamic analysts.

- The two cases also raised the awareness of the shortcomings in the analysis tools currently available. The significant difference between the predicted stability levels and the field measurements point to the need for further refinements in the models for floating oil film seals, dampers, labyrinth seals, and impeller forces.

- These cases also showed that one cannot assume replacing a component (oil film seals) with a relatively more reliable and trouble free component (dry gas seal) as being simple and straight forward. When making dry gas seal conversions, the rotordynamic analysis should include all parameters which have an influence on the stability of the compressor.

## REFERENCES

1. Childs, D., Nelson, C., Nicks, C., Scharrer, J., Elrod, D., and Hale, K., "Theory versus Experiment for the Rotordynamic Coefficients of Annular Gas Seals: Part I-Test Facility and Apparatus," *Journal of Tribology*, p.108, 426-432, (1986).
2. Childs, D., Elrod, D., and Hale, K., "Annular Honeycomb Seals: Test Results for Leakage and Rotordynamic Coefficients; Comparisons to Labyrinth and Smooth Configurations," *Journal of Tribology*, pp.111, 293-301, (1989).
3. Childs, D., Elrod, D., and Ramsey, C., "Annular Honeycomb Seals: Additional Test Results for Leakage and Rotordynamic Coefficients," in IFToMM, *Proceedings of the Third International Conference on Rotordynamics*. Lyon, France, pp. 303-312, (1990).
4. Vance, J. M., *Rotordynamics of Turbomachinery*, New York, New York, John Wiley & Sons (1988).
5. Tripp, H. A. and Murphy, B. T., "Eccentricity Measurements on a Tilting-Pad Bearing," *ASLE Trans.*, 28 (2), pp. 217-224 (April 1985).
6. Kanki, H., Katayama, K., Morri, S., Mouri, Y., Umemura, S., Ozawa, T., and Oda, T., "High Stability Design for New Centrifugal Compressor," *Rotordynamic Instability Workshop*, Texas A&M University, College Station, Texas, pp. 445-459 (1988).

7. Alford, J. S., "Protecting Turbomachinery From Self-Excited Rotor Whirl," *Journal of Engineering for Power*, Trans. ASME Series A, 87, pp. 333-339 (October 1965).
8. Wachel, J. C., "Rotordynamic Instability Field Problems," *Rotordynamic Instability Problems in High-Performance Turbomachinery*, Texas A&M University, NASA Conference Publication 2250, pp. 1-19 (1982).
9. Elrod, D., Series of personal correspondence with F. Y. Zeidan (1990).
10. Zhou, Ren-mu, "Instability of Multistage Compressor K1501," *Rotordynamic Instability Problems in High-Performance Turbomachinery*, Texas A&M University, NASA Conference Publication 2443, pp. 63-75 (1986).
11. Kocur, J. A., Platt, J. P., and Shabi, L. G., "Retrofit of Gas Lubricated Face Seals in a Centrifugal Compressor," *Proceedings of the Sixteenth Turbomachinery Symposium*, The Turbomachinery Laboratory, The Texas A&M University System, College Station, Texas, pp. 75-83 (1987).
12. Platt, J. P., Series of personal correspondence with F. Y. Zeidan (1990).
13. Childs, D. W., Consultation with F. Y. Zeidan (October 16, 1990).
14. Atkins, K. E. and Perez, R. X., "Influence of Gas Seals on Rotor Stability of a High Speed Hydrogen Recycle Compressor," *Proceedings of the Seventeenth Turbomachinery Symposium*, The Turbomachinery Laboratory, The Texas A&M University System, College Station, Texas, pp. 9-18 (1988).
15. Muszynska, A., *Modal Testing of Rotor/Bearing Systems*, Excerpts from Course Notes, Senior Mechanical Engineering Seminar, Bently Nevada Corp., Minden, Nevada (June 1987).
16. Atkins, K. E., Perez, R. X., and Turner, D. M. "A Simple Procedure for Assessing Rotor Stability," *Proceedings of the Third International Symposium on Transport Phenomena and Dynamics of Rotating Machinery*, Honolulu, Hawaii (1990).
17. Nelson, W. E., "Maintenance Techniques for Turbomachinery," *Proceedings of the Eighth Turbomachinery Symposium*, The Turbomachinery Laboratory, The Texas A&M University System, College Station, Texas, pp. 11-20 (1979).

## ACKNOWLEDGEMENTS

The authors wish to acknowledge the advice and assistance provided by Professor Dara W. Childs of the Turbomachinery Laboratory at Texas A&M University, which was instrumental in solving the stability problems in both of the cases presented. The authors of the first case are also indebted to Terry Ashmore for his persistence, dedication, and drive to carry out the modifications required to bring the compressor to the desired performance levels. The following individuals also contributed to solving the problems on the compressor presented in first case: John Kocur, John Platt, Larry Shabi, Gordon Kirk, and Jerry Hustak. All the modifications applied to the compressor were implemented in close cooperation with the OEM. The authors also wish to acknowledge Ken Atkins of EDI for his work in the straight through compressor case and for providing much of the analysis data for that case. Thanks are also due to Steve Carlu for assisting in the the preparation of schematics and drawings.

